

3-JAW WEDGE TYPE NON THROUGH-HOLE  
POWER CHUCK (WITH ADAPTOR)

Serration Pitch  
6"-18" : 1.5x60°  
21", 24" : 3.0x60°

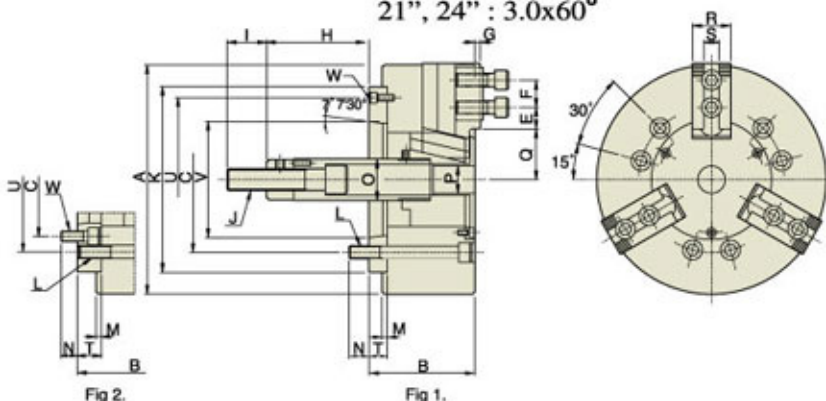

規格 SPECIFICATIONS

型號 Model	爪行程(直徑) Jaw Stroke (Dia) (mm)	柱塞行程 Plunger Stroke (mm)	最大推力 Max. Pull Force (kgf)	最大夾持力 油壓壓力 Max. Gripping Force (kgf)/(kgf/cm <sup>2</sup> )	最高轉速 Max. Speed (r.p.m)	重量 Weight (kg)	慣性矩 Moment of Inertia (kgf.m <sup>2</sup> )	適合油壓缸 Matching Cylinder	適合之軟爪 Matching Soft Jaw	適合之硬爪 Matching Hard Jaw
尺寸 Dim										
V-206A5	8.5	20	1835	5253/25.5	5270	12.5	0.045	MH105	HC06	HJ06
V-208A6	8.8	21	2549	7548/24.5	4765	24.4	0.137	MH125	HC08	HJ08
V-210A6	8.8	25	2957	10013/28.6	4010	40.65	0.3	MH125	HC10	HJ10
V-210A8	8.8	25	2957	10013/28.6	4010	37.15	0.3	MH125	HC10	HJ10
V-212A8	10.5	30	4181	15807/27.5	3380	61.75	0.725	MH150	HC12-1	HJ12-1
V-215A8	16	35	8362	25391/30.6	3000	105	1.8	MH150	HC15-1	HJ15-1
V-215A11	16	35	8362	25391/32.6	3000	103	1.8	MH200	HC15-1	HJ15-1
V-218A8	16	35	8362	25391/32.6	2700	134	2.41	MS-200	HC15-1	HJ15-1
V-218A11	16	35	8362	25391/32.6	2700	123	2.11	MS-200	HC15-1	HJ15-1
V-221A11	16	35	8362	25391/32.6	1900	193	5.1	MS-200	HC21-1	HJ21-1
V-221A15	16	35	8362	25391/32.6	1900	187	4.9	MS-200	HC21-1	HJ21-1
V-224A11	16	35	8362	25391/32.6	1750	239	7.5	MS-200	HC21-1	HJ21-1
V-224A15	16	35	8362	25391/32.6	1750	233	7.1	MS-200	HC21-1	HJ21-1

尺寸表 DIMENSIONS

型號 Model	V-206 A5	V-208 A5	V-208 A6	V-210 A6	V-210 A8	V-212 A8	V-215 A8	V-215 A11	V-218 A8	V-218 A11	V-221 A11	V-221 A15	V-224 A11	V-224 A15
尺寸 Dim														
A	165	210	210	254	254	304	381	381	450	450	530	530	610	610
B	84	103	97	109	102	118	141	130	141	130	146	146	146	146
C	104.78	104.78	133.35	133.35	171.45	171.45	171.45	235	171.45	235	235	330.2	235	330.2
F	20	25	25	30	30	30	43	43	43	43	60	60	60	60
K	140	170	170	220	220	220	300	300	300	300	380	380	380	380
L	6-M10	6-M12	6-M12	6-M16	6-M16	6-M16	6-M16	6-M20	6-M16	6-M20	6-M20	6-M24	6-M24	6-M24
M	5	5	5	5	5	6	6	6	6	6	6	6	6	6
N	14	13	18	18	25	25	24	32	24	32	28	34	28	34
P	21	21	25	34	34	34	-	-	-	-	-	-	-	-
T	15	23	17	25	18	18	33	22	33	22	27	27	27	27
V	82.563	82.563	106.375	106.375	139.719	139.719	139.719	196.869	139.719	196.869	196.869	285.75	196.869	285.75
U	116	133.35	150	171.45	190	190	235	260	235	260	330.2	330.2	330.2	330.2
E	Max.	18	22.5	22.5	37.5	37.5	47	50.25	50.25	50.25	50.25	93.5	93.5	93.5
	Min.	7.5	9	9	10.5	10.5	11	23.25	23.25	23.25	23.25	24.5	24.5	24.5
G	4	5	5	5	5	5	2	2	3	3	3	3	3	3
H	Max.	89.6	109	115	133	140	145	71	82	59	70	70	70	70
	Min.	69.6	88	94	108	115	36	47	24	35	35	35	35	35
I	36	36	36	36	36	36	55	55	55	55	55	55	55	55
J	M16x2.0	M20x2.5	M20x2.5	M20x2.5	M20x2.5	M20x2.5	M30x3.5	M30x3.5	M30x3.5	M30x3.5	M30x3.5	M30x3.5	M30x3.5	M30x3.5
O	34	38	38	45	45	50	60	60	60	60	60	60	60	60
Q	Max.	37.8	46.3	46.3	51.1	51.1	61	77.5	77.5	108	108	86	86	125
	Min.	33.5	41.9	41.9	46.7	46.7	55.75	69.5	69.5	100	100	78	78	117
R	31	35	35	40	40	50	50	50	50	50	65	65	65	65
S	12	14	14	16	16	18	25.5	25.5	25.5	25.5	25	25	25	25
W	3-M6	3-M10	3-M6	6-M12	6-M8	6-M8	6-M16	3-M10	6-M20	3-M10	6-M20	3-M12	6-M20	3-M12
參考圖 Reference	Fig-1	Fig-2	Fig-1	Fig-2	Fig-1	Fig-1	Fig-2	Fig-1	Fig-2	Fig-1	Fig-1	Fig-1	Fig-2	Fig-1