

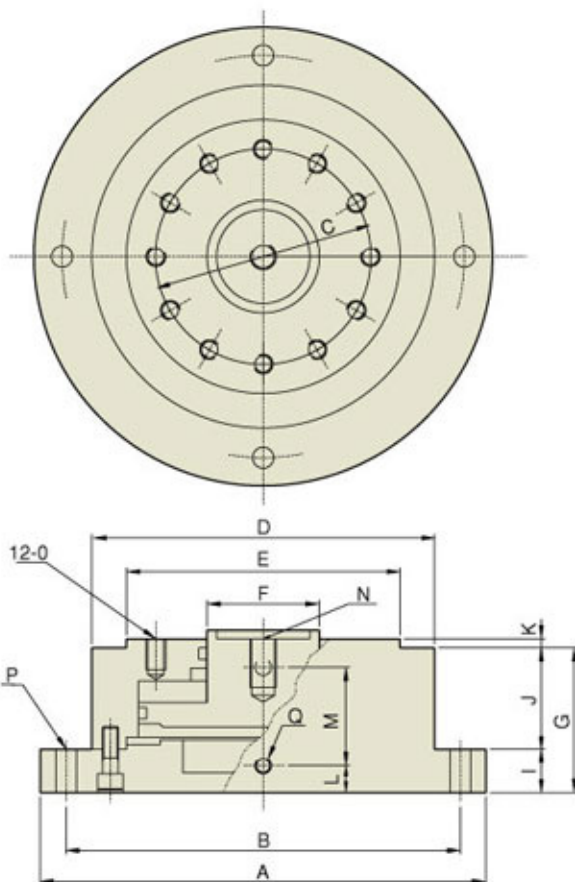

- 適合立式、鉗孔、銑削加工。
- Suitable for vertical milling and drilling operations.



■ 規格 SPECIFICATIONS

型式 Model	尺寸 Dim	活塞直徑 Piston Dia (mm)	活塞面積 Effective Piston Area		活塞行程 Piston Stroke (mm)	最大拉桿推力 Max. Draw Bar Pull		重量 Weight (kg)	最高使用油壓力 Max. Operating pressure (kgf/cm ²)	適用夾頭 Matching Chuck
			推側 Push Side (cm ²)	拉側 Pull Side (cm ²)		推側 Push Side (kgf)	拉側 Pull Side (kgf)			
6" 立式座 DOV		ø115	104	78.5	20	1900	1400	12	20	V206
8" 立式座 DOV		ø155	187	148.6	17	3600	2800	21	20	V208 V210

■ 尺寸表 DIMENSIONS

尺寸 Dim	型式 Model	6" 立式座 DOV	8" 立式座 DOV
A		220	285
B		205	250
C		Ø104.8	Ø133.4
D		ø168	ø210
E		ø140	ø170
F		ø55	ø70
G		60	80.5
I		16	24

尺寸 Dim	型式 Model	6" 立式座 DOV	8" 立式座 DOV
K		5.5	5.5
L		15	15
M		50	60
N		M14xP2.0	M16xP2.0
O		M12深24	M12深24
P		4-Ø13	4-Ø13
Q		PT1/4"	PT1/4"